

Kit 1461

- CHEVROLET Colorado**, 4-dr Double Cab, 04–
- CHEVROLET Colorado**, 4-dr Extended Cab, 04–
- CHEVROLET Colorado**, 4-dr Crew Cab, *04–
- CHEVROLET Colorado**, 4-dr Extra Cab, *04–
- GMC Canyon**, 4-dr Crew Cab, *04–
- GMC Canyon**, 4-dr Extra Cab, *04–
- GREAT WALL V240**, 4-dr Double Cab, 09–
- GREAT WALL Steed**, 4-dr Double Cab, 09–
- GREAT WALL Wingle**, 4-dr Double Cab, 06–
- ISUZU D-max**, 4-dr Double Cab, 02–
- ISUZU D-max**, 4-dr Extended Cab, 02–
- ISUZU I-280/I-290**, 4-dr Crew Cab, *06-09
- ISUZU I-350/I-370**, 4-dr Extra Cab, *06-09

*North America

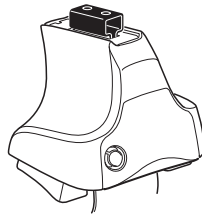

754 Rapid System
480R Rapid Traverse (North America)

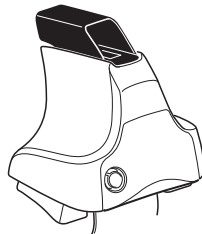
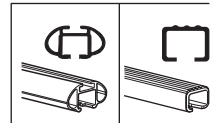

480 Traverse (North America)

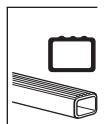

1

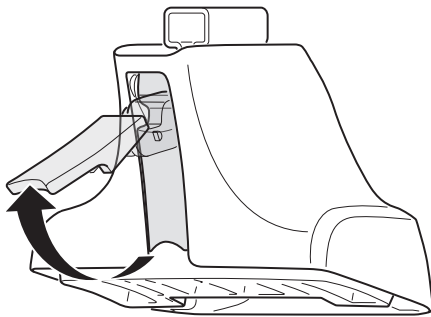

2



754 Rapid System
480R Rapid Traverse
(North America)

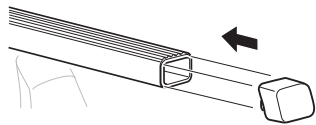
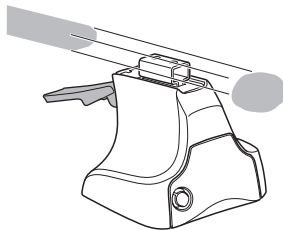

x4

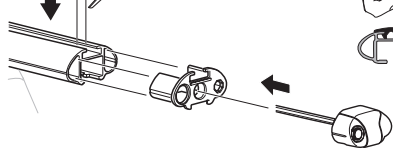
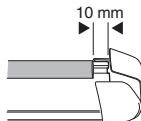

x4

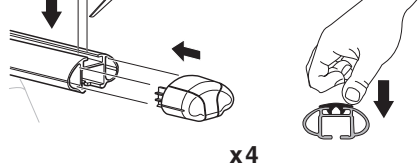
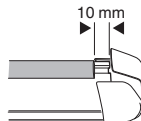

x4



480 Traverse
(North America)

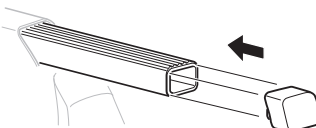
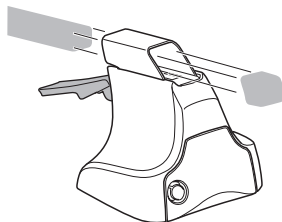

x4

3

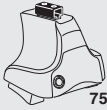

754 Rapid System

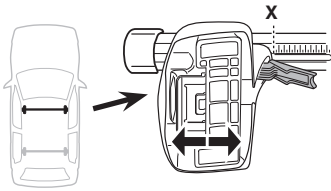

X

CHEVROLET Colorado, 4-dr Double Cab, 04-	34
CHEVROLET Colorado, 4-dr Extended Cab, 04-	34
CHEVROLET Colorado, 4-dr Crew Cab, *04-	34
CHEVROLET Colorado, 4-dr Extra Cab, *04-	34
GMC Canyon, 4-dr Crew Cab, *04-	34
GMC Canyon, 4-dr Extra Cab, *04-	34
GREAT WALL V240, 4-dr Double Cab, 09-	34
GREAT WALL Steed, 4-dr Double Cab, 09-	34
GREAT WALL Wingle, 4-dr Double Cab, 06-	34
ISUZU D-max, 4-dr Double Cab, 02-	34
ISUZU D-max, 4-dr Extended Cab, 02-	34
ISUZU I-280/I-290, 4-dr Crew Cab, *06-09	34
ISUZU I-350/I-370, 4-dr Extra Cab, *06-09	34

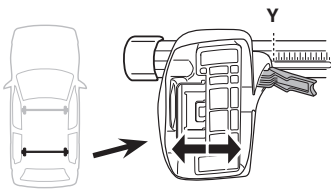

Y

CHEVROLET Colorado, 4-dr Double Cab, 04-	32
CHEVROLET Colorado, 4-dr Extended Cab, 04-	32
CHEVROLET Colorado, 4-dr Crew Cab, *04-	32
CHEVROLET Colorado, 4-dr Extra Cab, *04-	32
GMC Canyon, 4-dr Crew Cab, *04-	32
GMC Canyon, 4-dr Extra Cab, *04-	32
GREAT WALL V240, 4-dr Double Cab, 09-	32
GREAT WALL Steed, 4-dr Double Cab, 09-	32
GREAT WALL Wingle, 4-dr Double Cab, 06-	32
ISUZU D-max, 4-dr Double Cab, 02-	32
ISUZU D-max, 4-dr Extended Cab, 02-	32
ISUZU I-280/I-290, 4-dr Crew Cab, *06-09	32
ISUZU I-350/I-370, 4-dr Extra Cab, *06-09	32

4

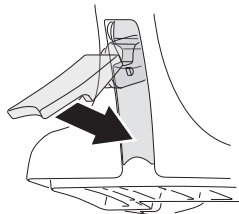

3



480 Traverse

(North America)

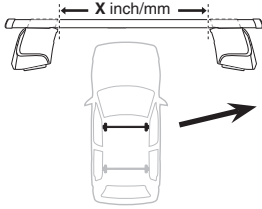

	X inch	X mm
CHEVROLET Colorado, 4-dr Double Cab, 04-	39"	991 mm
CHEVROLET Colorado, 4-dr Extended Cab, 04-	39"	991 mm
CHEVROLET Colorado, 4-dr Crew Cab, *04-	39"	991 mm
CHEVROLET Colorado, 4-dr Extra Cab, *04-	39"	991 mm
GMC Canyon, 4-dr Crew Cab, *04-	39"	991 mm
GMC Canyon, 4-dr Extra Cab, *04-	39"	991 mm
GREAT WALL V240, 4-dr Double Cab, 09-	39"	991 mm
GREAT WALL Steed, 4-dr Double Cab, 09-	39"	991 mm
GREAT WALL Wingle, 4-dr Double Cab, 06-	39"	991 mm
ISUZU D-max, 4-dr Double Cab, 02-	39"	991 mm
ISUZU D-max, 4-dr Extended Cab, 02-	39"	991 mm
ISUZU I-280/I-290, 4-dr Crew Cab, *06-09	39"	991 mm
ISUZU I-350/I-370, 4-dr Extra Cab, *06-09	39"	991 mm

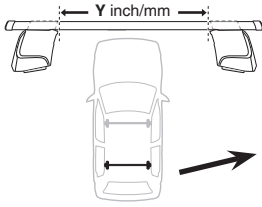

	Y inch	Y mm
CHEVROLET Colorado, 4-dr Double Cab, 04-	38 ¹ / ₄ "	971 mm
CHEVROLET Colorado, 4-dr Extended Cab, 04-	38 ¹ / ₄ "	971 mm
CHEVROLET Colorado, 4-dr Crew Cab, *04-	38 ¹ / ₄ "	971 mm
CHEVROLET Colorado, 4-dr Extra Cab, *04-	38 ¹ / ₄ "	971 mm
GMC Canyon, 4-dr Crew Cab, *04-	38 ¹ / ₄ "	971 mm
GMC Canyon, 4-dr Extra Cab, *04-	38 ¹ / ₄ "	971 mm
GREAT WALL V240, 4-dr Double Cab, 09-	38 ¹ / ₄ "	971 mm
GREAT WALL Steed, 4-dr Double Cab, 09-	38 ¹ / ₄ "	971 mm
GREAT WALL Wingle, 4-dr Double Cab, 06-	38 ¹ / ₄ "	971 mm
ISUZU D-max, 4-dr Double Cab, 02-	38 ¹ / ₄ "	971 mm
ISUZU D-max, 4-dr Extended Cab, 02-	38 ¹ / ₄ "	971 mm
ISUZU I-280/I-290, 4-dr Crew Cab, *06-09	38 ¹ / ₄ "	971 mm
ISUZU I-350/I-370, 4-dr Extra Cab, *06-09	38 ¹ / ₄ "	971 mm

4

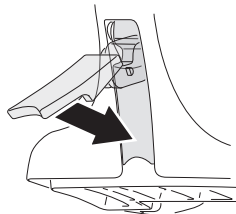

5

CHEVROLET Colorado, 4-dr Double Cab, 04–
CHEVROLET Colorado, 4-dr Extended Cab, 04–
CHEVROLET Colorado, 4-dr Crew Cab, *04–
CHEVROLET Colorado, 4-dr Extra Cab, *04–
GMC Canyon, 4-dr Crew Cab, *04–
GMC Canyon, 4-dr Extra Cab, *04–
GREAT WALL V240, 4-dr Double Cab, 09–

GREAT WALL Steed, 4-dr Double Cab, 09–
GREAT WALL Wingle, 4-dr Double Cab, 06–
ISUZU D-max, 4-dr Double Cab, 02–
ISUZU D-max, 4-dr Extended Cab, 02–
ISUZU I-280/I-290, 4-dr Crew Cab, *06-09
ISUZU I-350/I-370, 4-dr Extra Cab, *06-09

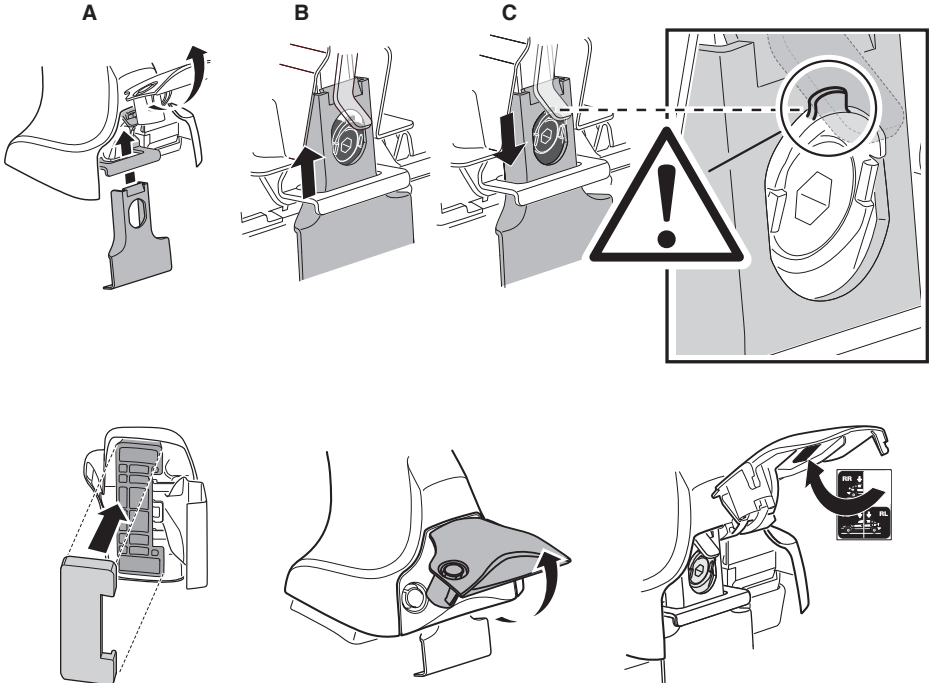
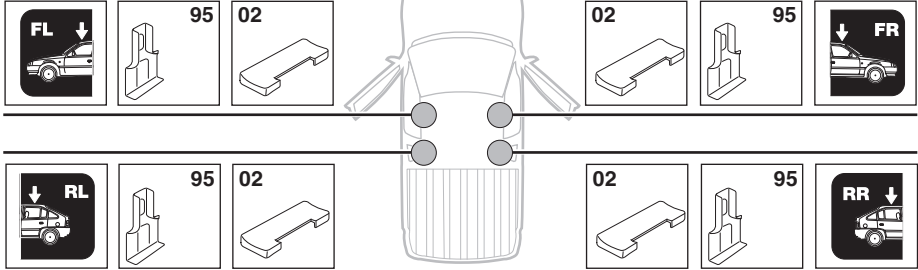

6

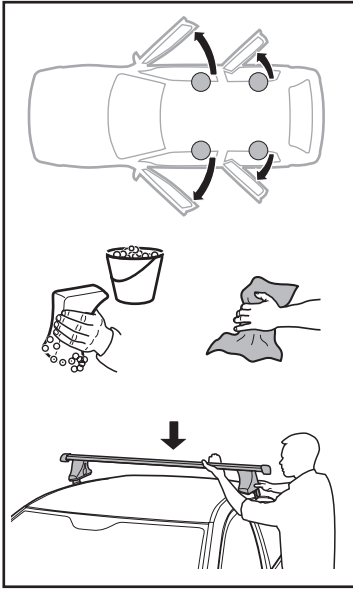

i

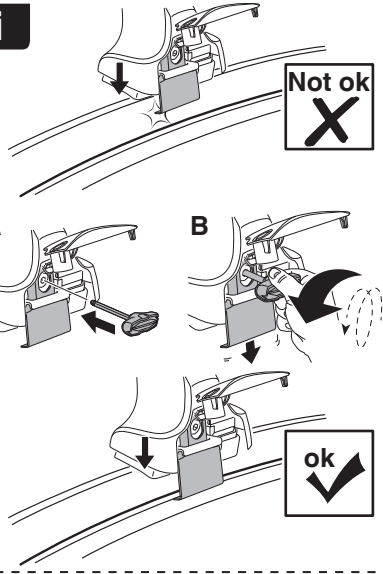

	X mm	Y mm	X inch	Y inch
CHEVROLET Colorado, 4-dr Double Cab, 04-	380 mm	750 mm	15 "	29 1/2 "
CHEVROLET Colorado, 4-dr Extended Cab, 04-	250 mm	680 mm	9 7/8 "	26 3/4 "
CHEVROLET Colorado, 4-dr Crew Cab, *04-	380 mm	750 mm	15 "	29 1/2 "
CHEVROLET Colorado, 4-dr Extra Cab, *04-	250 mm	680 mm	9 7/8 "	26 3/4 "
GMC Canyon, 4-dr Crew Cab, *04-	380 mm	750 mm	15 "	29 1/2 "
GMC Canyon, 4-dr Extra Cab, *04-	250 mm	680 mm	9 7/8 "	26 3/4 "
GREAT WALL V240, 4-dr Double Cab, 09-	380 mm	650 mm	15 "	25 5/8 "
GREAT WALL Steed, 4-dr Double Cab, 09-	380 mm	650 mm	15 "	25 5/8 "
GREAT WALL Wingle, 4-dr Double Cab, 06-	380 mm	650 mm	15 "	25 5/8 "
ISUZU D-max, 4-dr Double Cab, 02-	380 mm	750 mm	15 "	29 1/2 "
ISUZU D-max, 4-dr Extended Cab, 02-	250 mm	680 mm	9 7/8 "	26 3/4 "
ISUZU I-280/I-290, 4-dr Crew Cab, *06-09	380 mm	750 mm	15 "	29 1/2 "
ISUZU I-350/I-370, 4-dr Extra Cab, *06-09	250 mm	680 mm	9 7/8 "	26 3/4 "

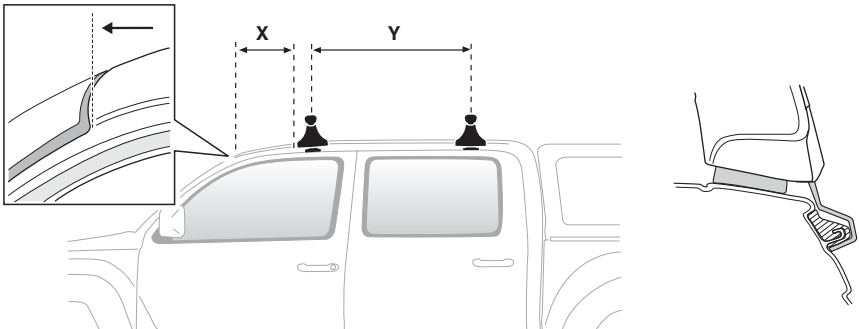

7

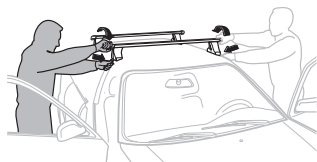

GB/US Tighten alternately
 D Die Schrauben abwechselnd anziehen
 F Serrer alternativement chaque côté
 NL Afwisselend aan de linker- en de rechterkant aandraaien
 I Alternare il serraggio delle viti
 E Apretar alternativamente
 PT Aperte alternadamente
 S Dra åt växelvis
 FIN Kierrä vuorotellen
 EST Pinguldage vaheldumisi
 LAT Pieļieciet pamišus
 LIT Užsukinėkite pakaitomis
 PL Śruby dokręcaj naprzemiennie
 RU Затягивайте попеременно

CZ Pokręťta bagażnika dokręcaj dokręcaj naprzemiennie.
 SK Dofahajte striedavo
 SLO Privijajte izmenično.
 HR Naizmjerno zategnite
 HU Egymástól függetlenül szorítandó
 GR Σφιγγείτε εναλλάξ
 TR Dönüşümlü sıkın

中文 交替拧紧

한국어 번갈아 가며 조이십시오.

日本語 交互に締め付けてください。

ไทย ชันในแบบสลับ

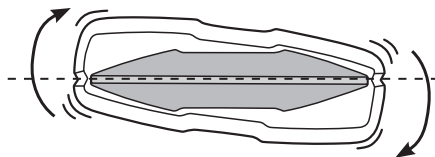
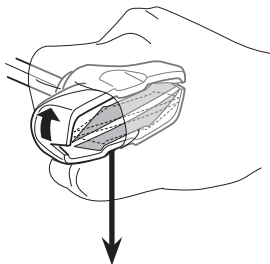
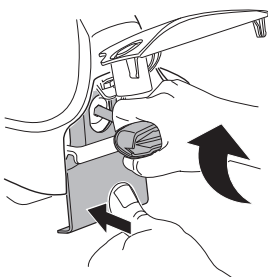
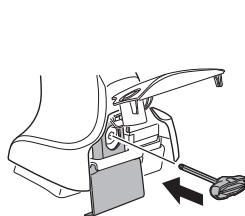

≈ 3 Nm

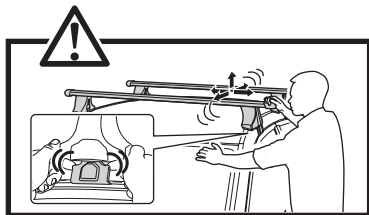
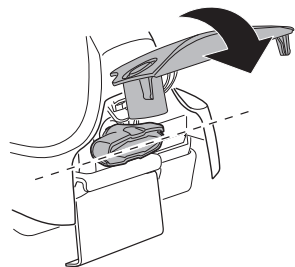

8



x1
17 mm

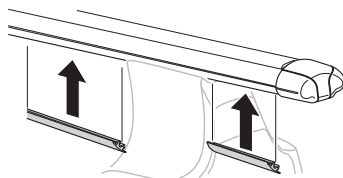
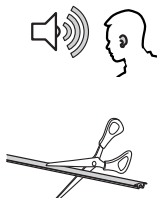

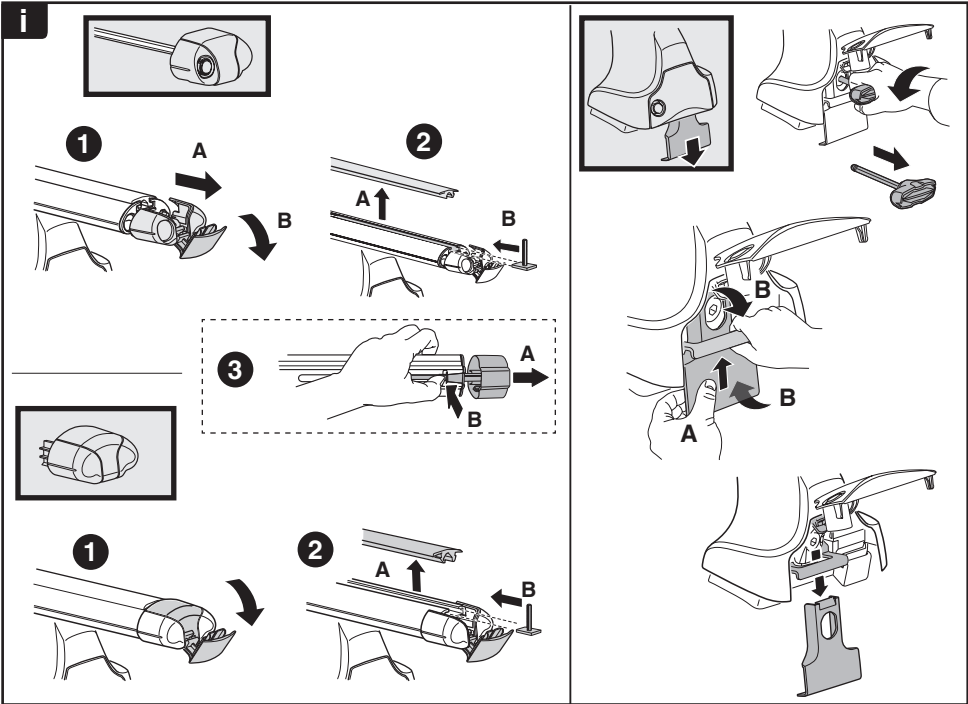
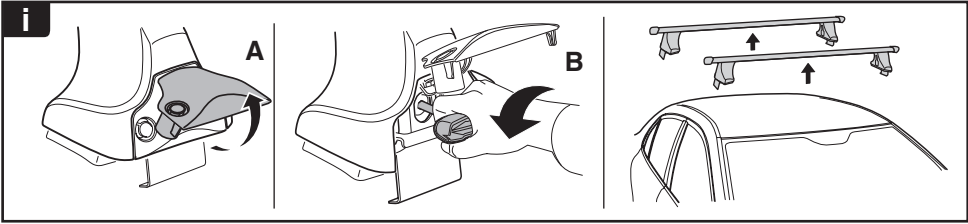

THULE
SWEDEN
**ONE
KEY
SYSTEM**

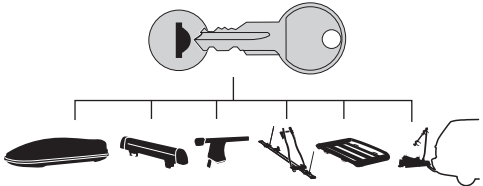

		544	(x4)
		596	(x6)
		588	(x8)
NA		510	(x10)
EUR		452	(x12)
ASIA			

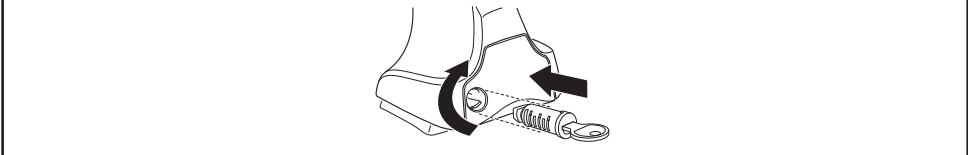

WW ▶ Thule Sweden AB, Box 69, 330 33 Hillerstorp, SWEDEN
NA ▶ Thule Inc., 42 Silvermine Road, Seymour, Connecticut 06483, USA

info@thule.com
customer.service@thule.com

www.thule.com

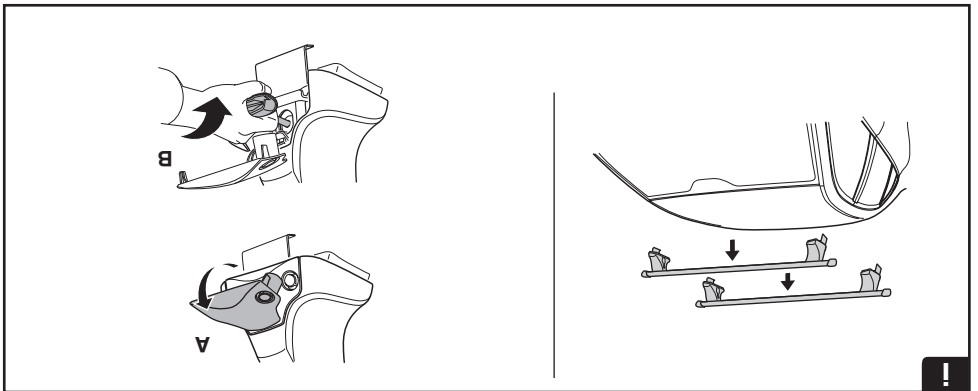
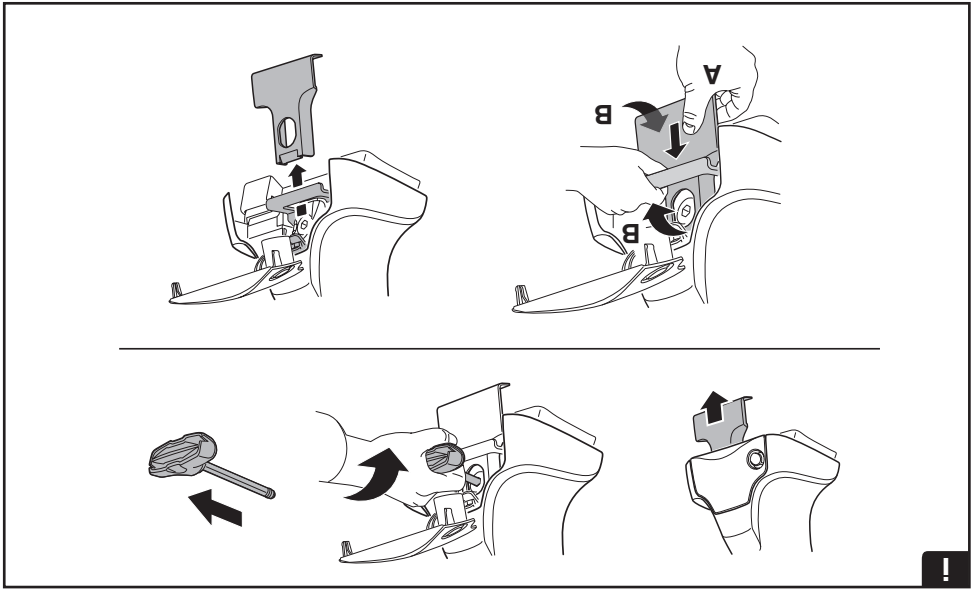

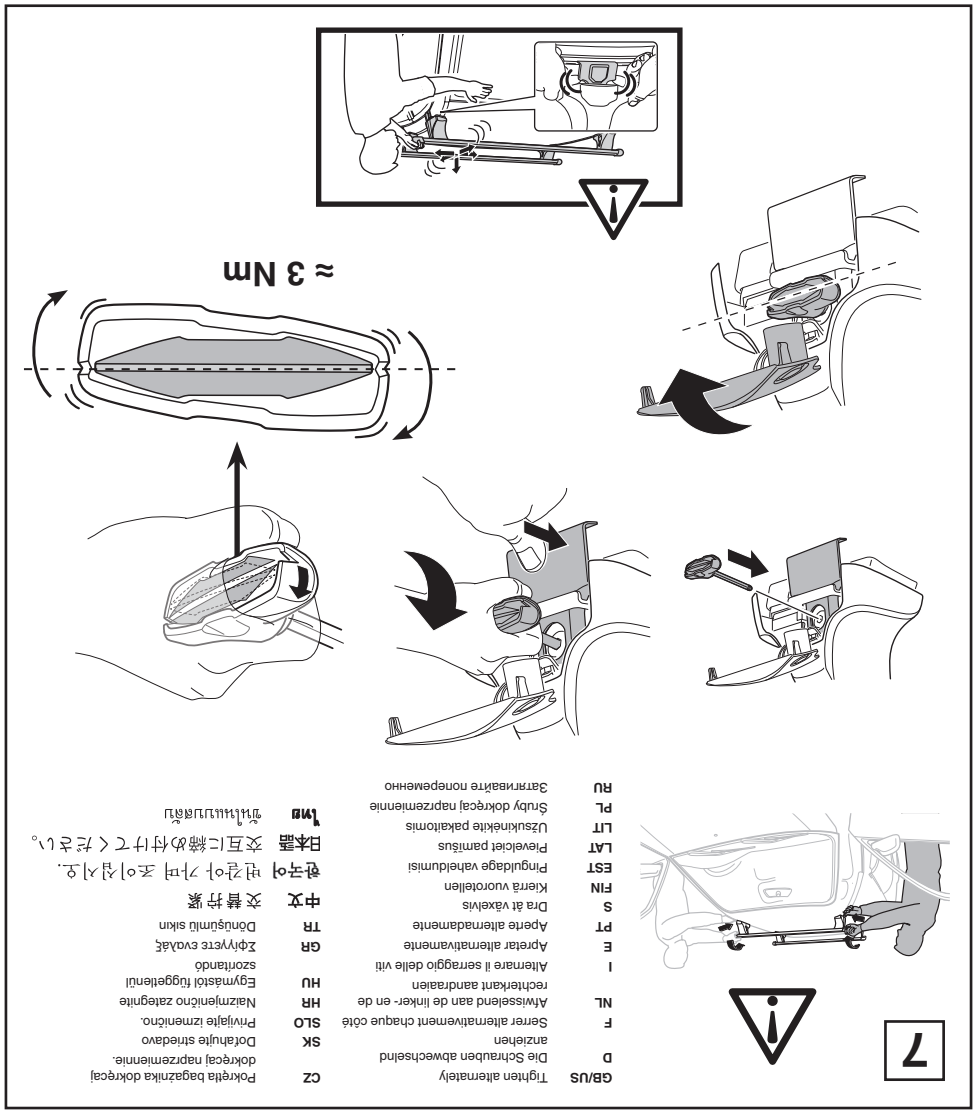
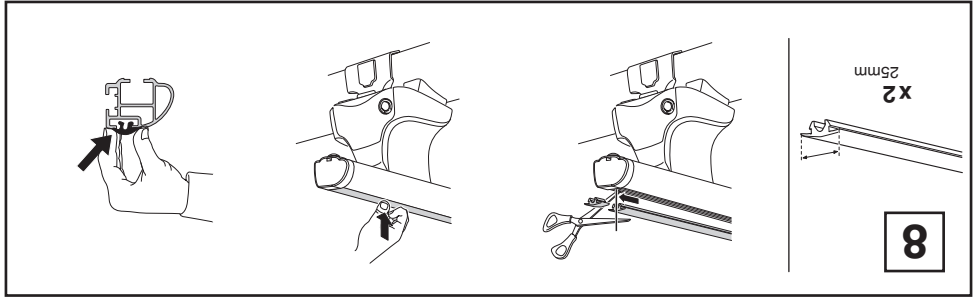

CZ Pokrétla bagazníka dokrecaj dokrecaj naprazmeniemie.

SK Dotiahnuť striedavo.

SLO Privajlajte izmenično.

HR Natzmenično zategnite.

HU Egymástól függetlenül szorítsandó.

GR Zpřilyžete evažáđ.

TR Dönüştürmlü sıkın.

中文 交替拧紧

한국어 번갈아가며 조이십시오.

日本語 交互に締め付けてください。

ไทย ไขสลับกัน

GB/US Tighten alternately

D Die Schrauben abwechselnd anziehen

F Serrer alternativement chaque côté

NL Afwisselend aan de linker- en de rechterkant aandraaien

I Alternare il serraggio delle viti

E Apretar alternativamente

PT Aperte alternadamente

S Dra åt växelvis

FIN Kierrä vuorotellen

EST Pinguldage vaheldumisi

LAT Pveiclot patīstus

LIT Užskinkite pakaitomis

PL Śrubę dokrecaj naprzemiennie

RU Затягивайте попеременно

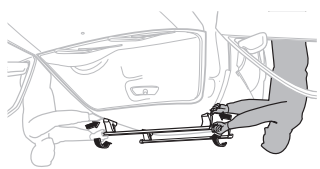

7

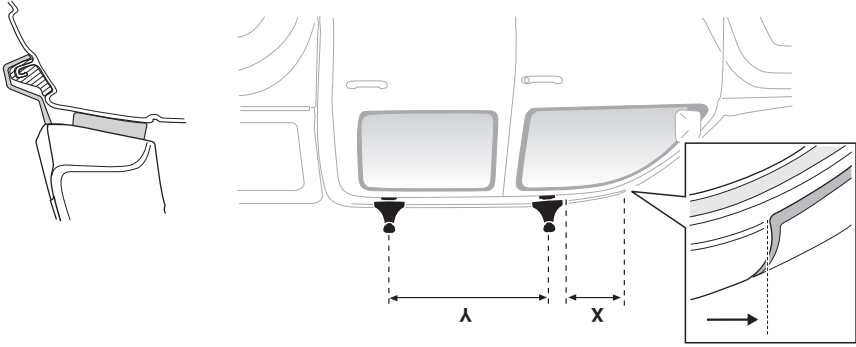

CHEVROLET Colorado, 4-dr Double Cab, 04-	380 mm	750 mm	15 "	29 1/2 "
CHEVROLET Colorado, 4-dr Extended Cab, 04-	250 mm	680 mm	9 7/8 "	26 3/4 "
CHEVROLET Colorado, 4-dr Crew Cab, 04-	380 mm	750 mm	15 "	29 1/2 "
CHEVROLET Colorado, 4-dr Extra Cab, 04-	250 mm	680 mm	9 7/8 "	26 3/4 "
GMC Canyon, 4-dr Crew Cab, 04-	380 mm	750 mm	15 "	29 1/2 "
GMC Canyon, 4-dr Extra Cab, 04-	250 mm	680 mm	9 7/8 "	26 3/4 "
GREAT WALL V240, 4-dr Double Cab, 09-	380 mm	650 mm	15 "	25 5/8 "
GREAT WALL Steed, 4-dr Double Cab, 09-	380 mm	650 mm	15 "	25 5/8 "
GREAT WALL Wingle, 4-dr Double Cab, 06-	380 mm	650 mm	15 "	25 5/8 "
ISUZU D-max, 4-dr Double Cab, 02-	380 mm	750 mm	15 "	29 1/2 "
ISUZU D-max, 4-dr Extended Cab, 02-	250 mm	680 mm	9 7/8 "	26 3/4 "
ISUZU I-280/I-290, 4-dr Crew Cab, 06-09	380 mm	750 mm	15 "	29 1/2 "
ISUZU I-350/I-370, 4-dr Extra Cab, 06-09	250 mm	680 mm	9 7/8 "	26 3/4 "

X mm Y mm X inch Y inch

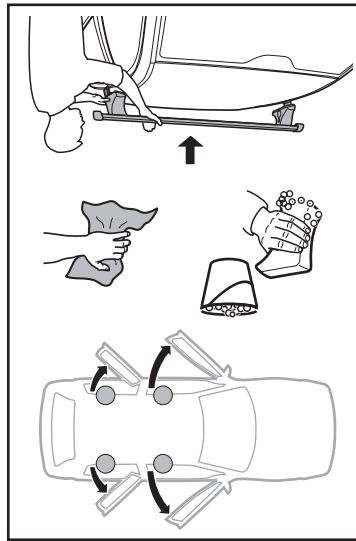
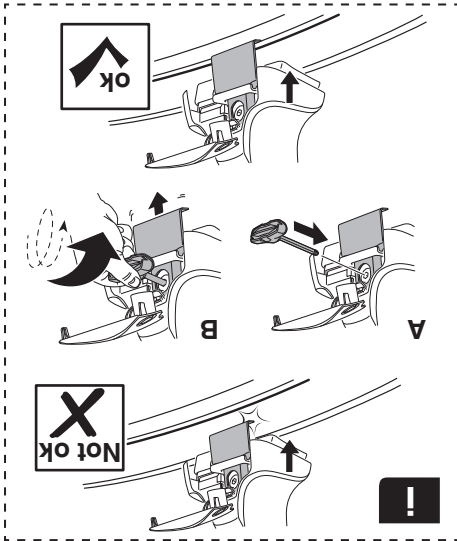

6

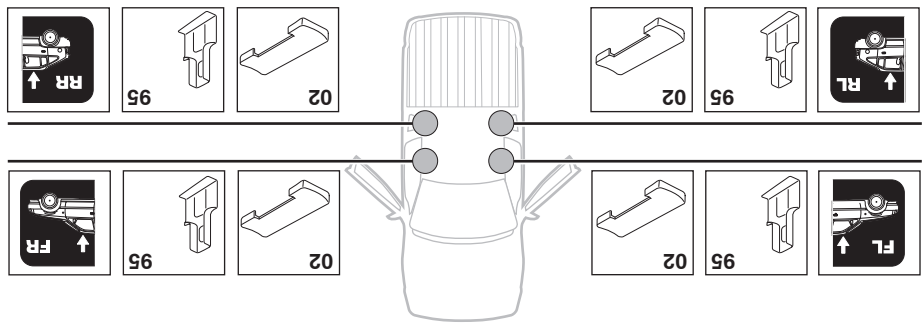
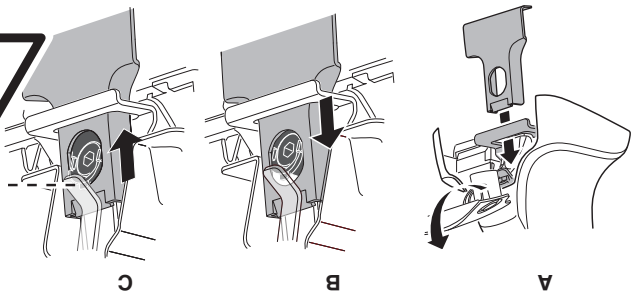
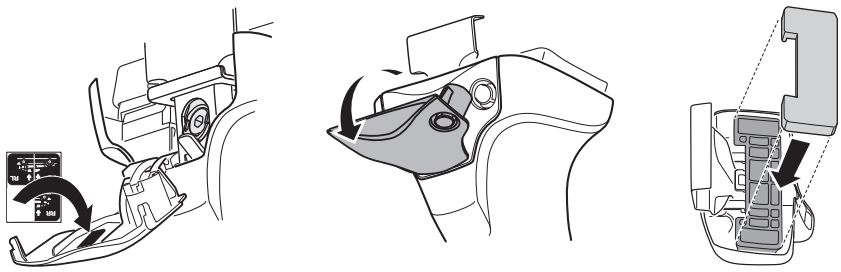

5

- CHEVROLET Colorado, 4-dr Double Cab, 04-
- CHEVROLET Colorado, 4-dr Extended Cab, 04-
- CHEVROLET Colorado, 4-dr Crew Cab, *04-
- CHEVROLET Colorado, 4-dr Extra Cab, *04-
- GMC Canyon, 4-dr Crew Cab, *04-
- GMC Canyon, 4-dr Extra Cab, *04-
- GREAT WALL V240, 4-dr Double Cab, 09-
- GREAT WALL Steed, 4-dr Double Cab, 09-
- GREAT WALL Wingle, 4-dr Double Cab, 06-
- ISUZU D-max, 4-dr Double Cab, 02-
- ISUZU D-max, 4-dr Extended Cab, 02-
- ISUZU I-280/I-290, 4-dr Crew Cab, *06-09
- ISUZU I-350/I-370, 4-dr Extra Cab, *06-09

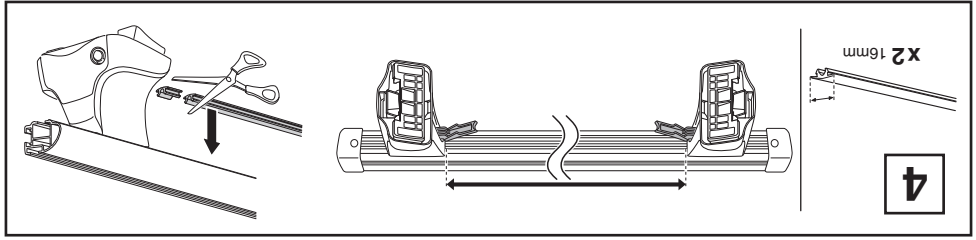

CHEVROLET Colorado, 4-dr Double Cab, 04-	38 1/4"	Y mm
CHEVROLET Colorado, 4-dr Extended Cab, 04-	38 1/4"	Y mm
CHEVROLET Colorado, 4-dr Crew Cab, 04-	38 1/4"	Y mm
CHEVROLET Colorado, 4-dr Extra Cab, 04-	38 1/4"	Y mm
GMC Canyon, 4-dr Crew Cab, 04-	38 1/4"	Y mm
GMC Canyon, 4-dr Extra Cab, 04-	38 1/4"	Y mm
GREAT WALL V240, 4-dr Double Cab, 09-	38 1/4"	Y mm
GREAT WALL Steed, 4-dr Double Cab, 09-	38 1/4"	Y mm
GREAT WALL Wingle, 4-dr Double Cab, 06-	38 1/4"	Y mm
ISUZU D-max, 4-dr Double Cab, 02-	38 1/4"	Y mm
ISUZU D-max, 4-dr Extended Cab, 02-	38 1/4"	Y mm
ISUZU I-280/I-290, 4-dr Crew Cab, 06-09	38 1/4"	Y mm
ISUZU I-350/I-370, 4-dr Extra Cab, 06-09	38 1/4"	Y mm

1 **2**

CHEVROLET Colorado, 4-dr Double Cab, 04-	39"	X mm
CHEVROLET Colorado, 4-dr Extended Cab, 04-	39"	X mm
CHEVROLET Colorado, 4-dr Crew Cab, 04-	39"	X mm
CHEVROLET Colorado, 4-dr Extra Cab, 04-	39"	X mm
GMC Canyon, 4-dr Crew Cab, 04-	39"	X mm
GMC Canyon, 4-dr Extra Cab, 04-	39"	X mm
GREAT WALL V240, 4-dr Double Cab, 09-	39"	X mm
GREAT WALL Steed, 4-dr Double Cab, 09-	39"	X mm
GREAT WALL Wingle, 4-dr Double Cab, 06-	39"	X mm
ISUZU D-max, 4-dr Double Cab, 02-	39"	X mm
ISUZU D-max, 4-dr Extended Cab, 02-	39"	X mm
ISUZU I-280/I-290, 4-dr Crew Cab, 06-09	39"	X mm
ISUZU I-350/I-370, 4-dr Extra Cab, 06-09	39"	X mm

1 **2**

3

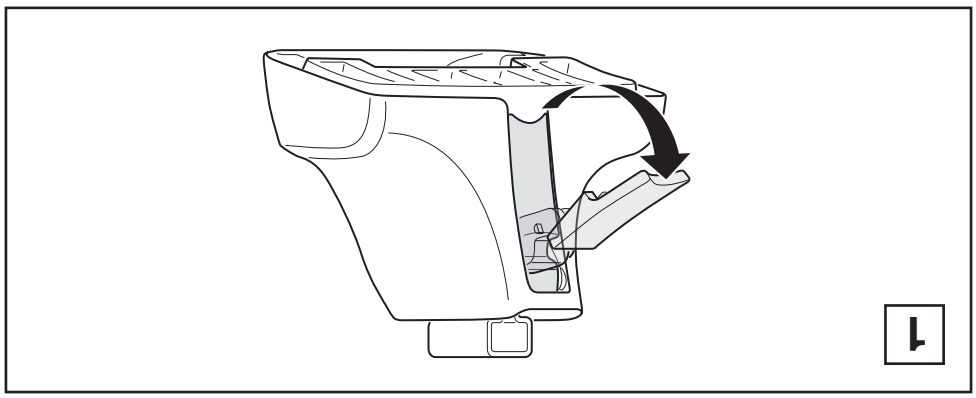
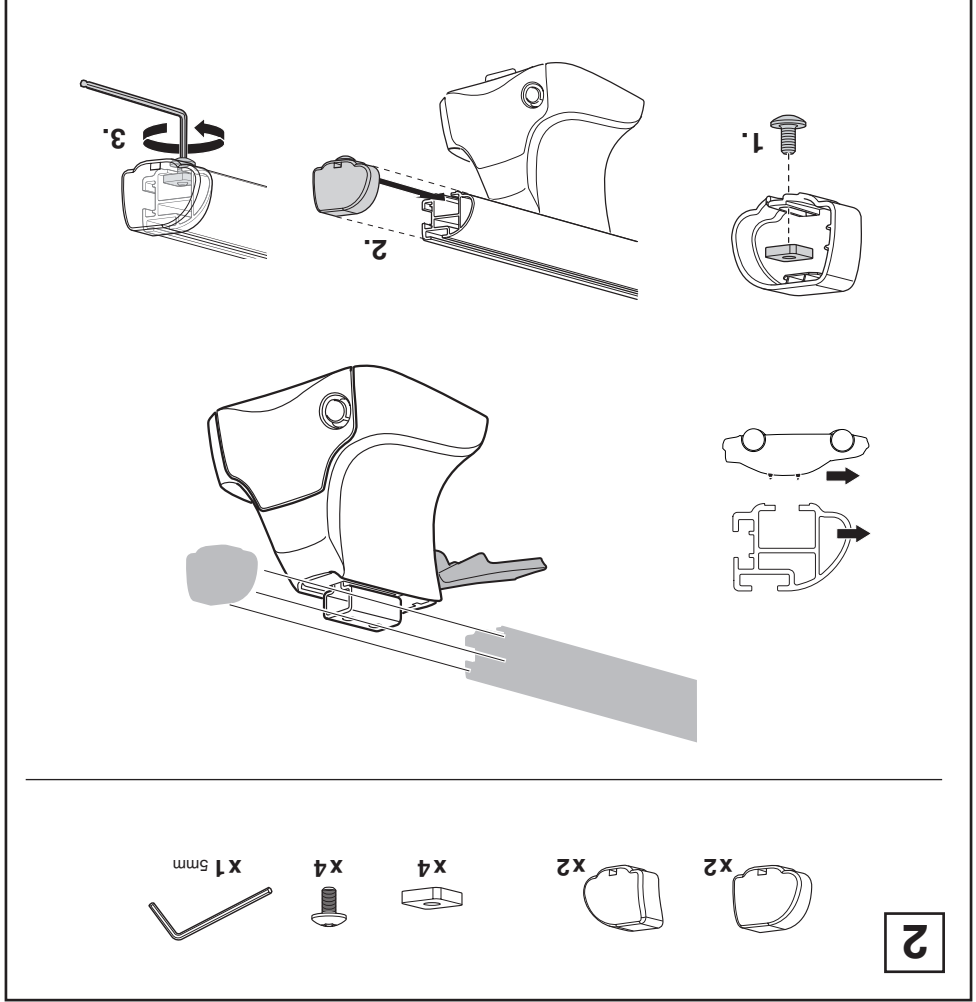

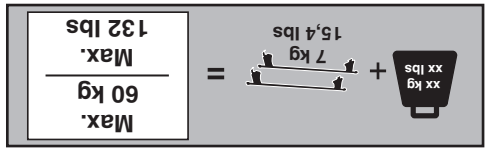
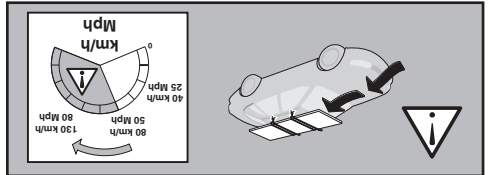
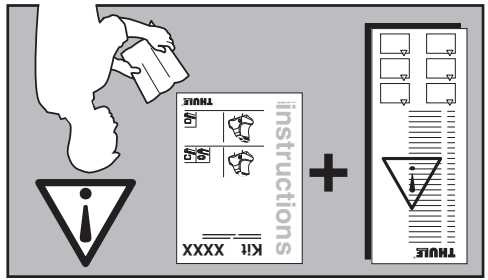
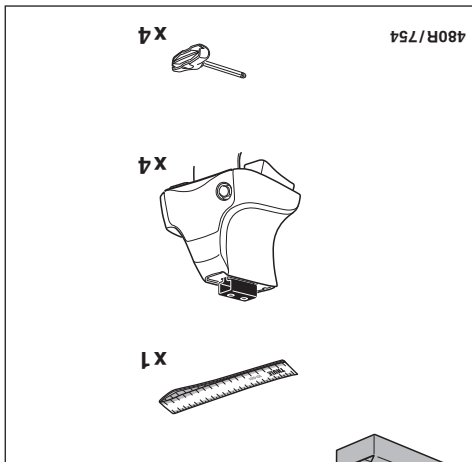
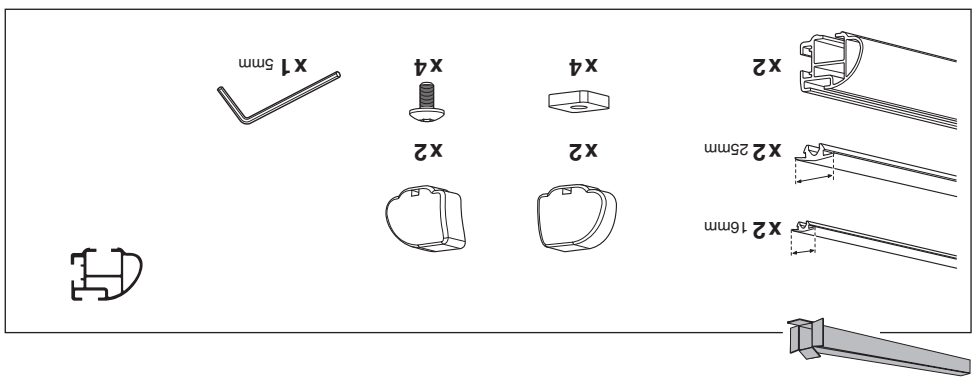
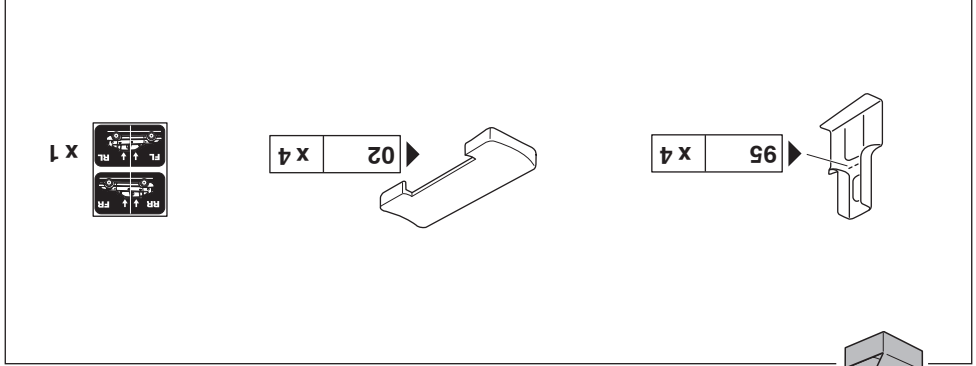

instructions

Kit 1461

- CHEVROLET Colorado, 4-dr Double Cab, 04-
- CHEVROLET Colorado, 4-dr Extended Cab, 04-
- CHEVROLET Colorado, 4-dr Crew Cab, *04-
- CHEVROLET Colorado, 4-dr Extra Cab, *04-
- GMC Canyon, 4-dr Crew Cab, *04-
- GMC Canyon, 4-dr Extra Cab, *04-
- GREAT WALL V240, 4-dr Double Cab, 09-
- GREAT WALL Steed, 4-dr Double Cab, 09-
- GREAT WALL Wingle, 4-dr Double Cab, 06-
- ISUZU D-max, 4-dr Double Cab, 02-
- ISUZU D-max, 4-dr Extended Cab, 02-
- ISUZU I-280/I-290, 4-dr Crew Cab, *06-09
- ISUZU I-350/I-370, 4-dr Extra Cab, *06-09

*North America

480R
754

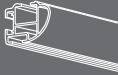
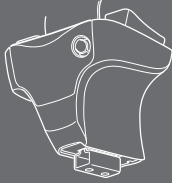

ISO 11154-E

PROFESSIONAL

THULE
SWEDEN®