



FITTING INSTRUCTIONS FOR
HYUNDAI i30 Hatch May '12 on
GTX Removable Roof Racks
PART NUMBER: **GTX082A**
FITTING TIME: EST. 15 MINUTES





ROOF-RACK LOADING CAPACITY: **60kgs**

ISSUE: A

ISSUE RELEASE DATE: 29/06/2012

TOTAL NUMBER OF PAGES INCLUDING COVERSHEET: 5

2. KIT DRAWING AND CONTENTS

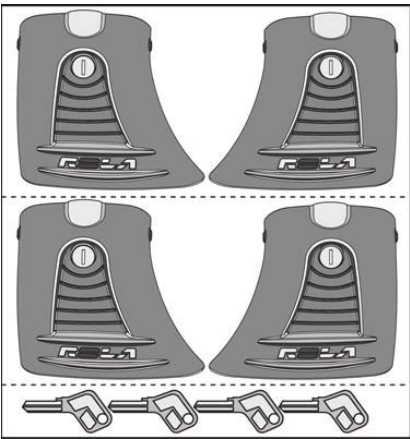
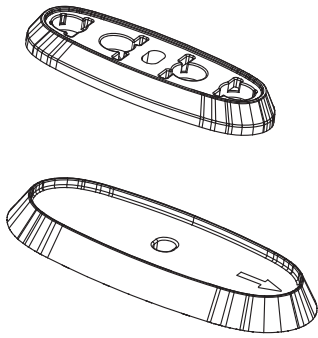
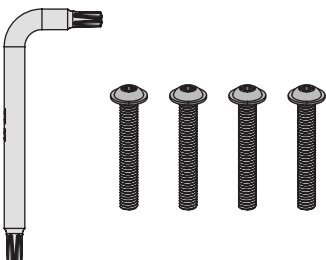
ITEM NO.	PARTS	QTY	DESCRIPTION
1	 <p>LENGTH = 925mm S Curve</p>	x1	ROOF-RACK CROSS-BAR ASSY (FRONT)
2	 <p>LENGTH = 895mm S Curve</p>	x1	ROOF-RACK CROSS-BAR ASSY (REAR)
3		x1	ROLA END SUPPORT COVER KIT (SET OF 4) (25-0150) - LEFT COVERS x2 - RIGHT COVERS x2 - KEYS
4		x4	PLASTIC ADAPTOR BLOCK (27-0717) ADAPTOR BLOCK GASKET (27-0718)
5		x1	HARDWARE KIT - TT27 ASSEMBLY KEY x1 (22-0811) - M6x55mm STAR HEAD BOLT x4 (22-0493)

3. TOOLS AND MATERIALS REQUIRED

 <p>Cutting Knife - Use to open Kits, and trim Buffer Strip to size.</p>	 <p>Measuring Rule - Use to check dimensions and distances of cross-bars.</p>	 <p>Cleaning/protective Cloth - Use to wipe down vehicle, and use to protect vehicle paint.</p>	 <p>Marking Pencil - Use to mark buffer strip.</p>	 <p>Phillips Head Screwdriver - Use to assemble Cross Bars</p>
--	---	---	--	--

4. INSTALLATION STEPS

Prior to Assembly, check that your Roof Rack Box contains all the parts as listed above. Ensure the vehicle roof is clean and dry. Use Knife to cut through the packaging polybags.

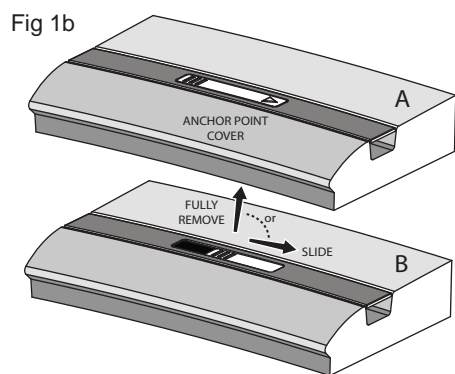
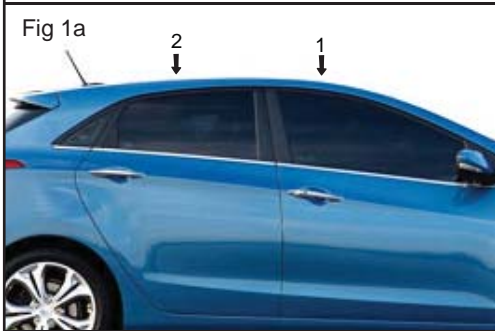

STEP 1

On the vehicle roof you will find 4 Anchor Point Covers paired in two locations indicated by the arrows in Fig 1a. Carefully remove these covers by sliding in the direction shown on the cover, to reveal the anchor points (Fig 1b). It is advisable to screw the Special Bolts into the Anchor Points at this time to clean the threads.

- ⚠ NOTE: Take care when removing to avoid damaging Trim Cover Clip. Covers can not be replaced while rack is fitted.
- ⚠ For a Single-Bar fitment, only remove the two Front or the two Rear covers, depending on the fitment.
- ⚠ Store the Anchor Point Covers and plugs safely while the Roof Racks are in use.

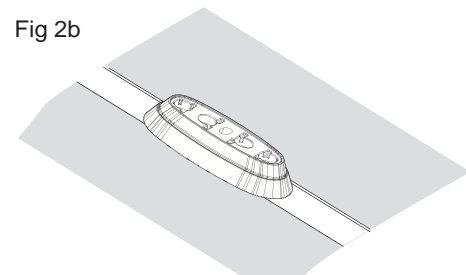
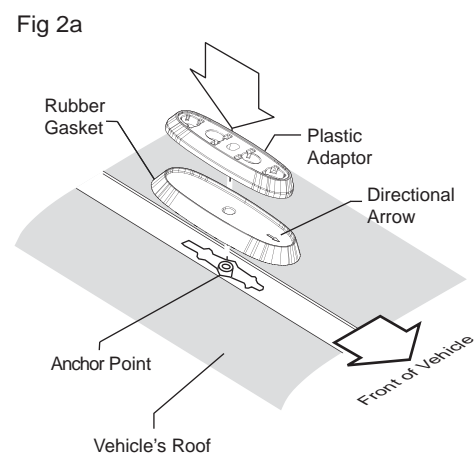

STEP 2

Replace an Anchor Point Cover, From STEP 1, with one of the supplied Rubber Gaskets

- ⚠ Ensure the Rubber Gasket is oriented correctly (Fig. 2a).
- ⚠ Each Rubber Gasket is marked with a directional arrow (Fig. 2a).
- ⚠ Ensure that the center hole in the gasket lines up with the anchor point thread in the roof.
For the front anchor point use the forward most threaded point.
For the rear anchor point use the rearward most threaded point

Locate the Plastic Multi Pad onto the Rubber Gasket

- ⚠ Ensure the Multi Pad is oriented correctly (Fig. 2b).
- ⚠ Ensure that the center hole in the Multi Pad lines up with the anchor point thread in the roof.

Repeat for all remaining Adaptors.

Fig 4

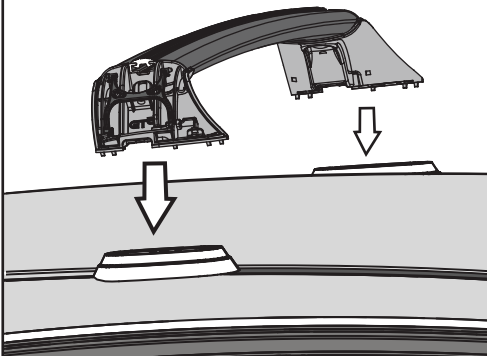

STEP 4

Place the front and rear cross-bars onto their respective bases. (Fig 4).

The front cross-bar is identified with a “FRONT” sticker located on the underside of the bar.

Make sure the End Supports and Adaptors have fully engaged.

Fig 5

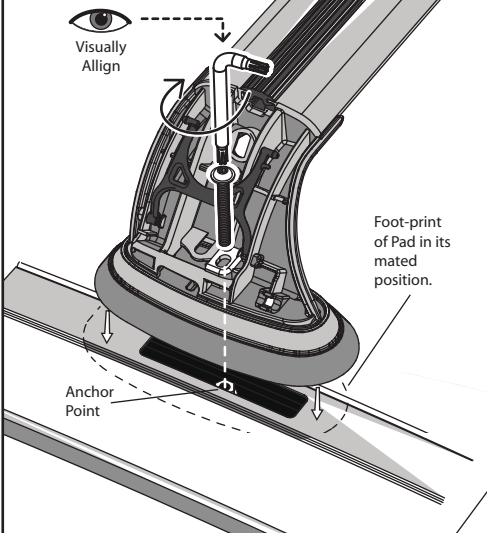

STEP 5

Visually align the following: End Support, End Support Adaptor, Rubber Gasket Adaptor Pad & Anchor Point.

Loosely secure the end support to the anchor point using a 55mm bolt supplied. Tighten approximately 2-3 turns.

Repeat for all end supports.

Using the Assembly Key provided tighten all M6 55mm bolts to a firm hand tightness, (5 Nm).

Use this tool

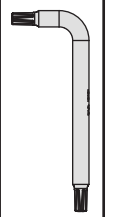
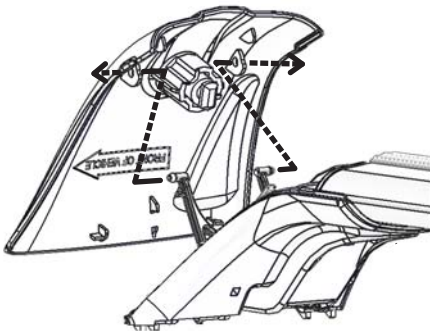

Fig 6



STEP 6

Locate ends of hinge with corresponding mount holes on the underside of the Covers. Flex hinge ends together and line up with cover mount holes. Push ends through holes until capped heads of hinge have entirely pushed through. (Fig 6).

Fig 7

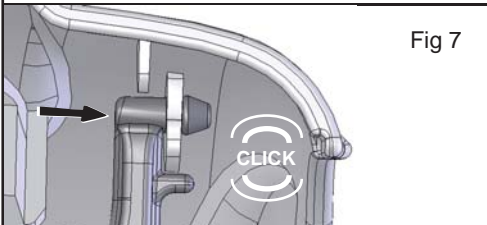

STEP 7

Ensure hinge has been mounted correctly by pushing ends through until you hear an “audible” click. (Fig 7).

Fig 8

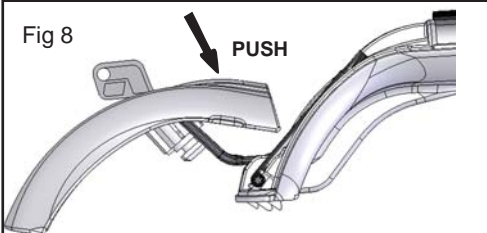

STEP 8

Fully extend the cover away from the End Support. Pivot the cover on its hinge whilst pushing the top downwards, until the cover is held fixed. (Fig 8).

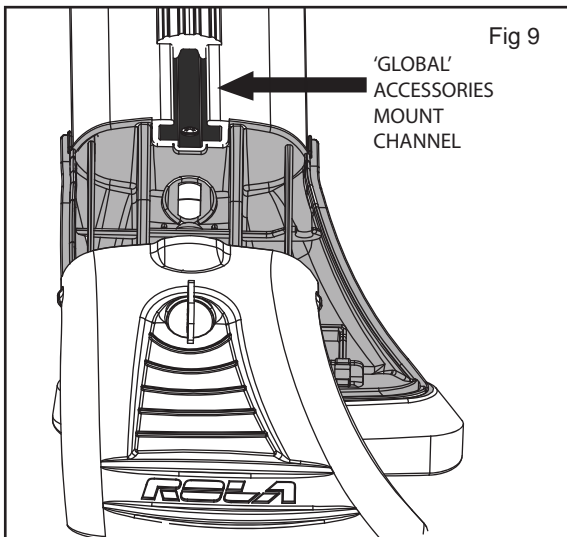

Fig 9

'GLOBAL'
ACCESSORIES
MOUNT
CHANNEL

STEP 9



You are now ready to mount your accessories, eg. Bike Carrier, Kayak carrier, etc. utilising the "Global Channel" if applicable. (Fig. 9).

Place the accessory onto the buffer strip in the location where it will be mounted in relation to your cross-bars. Using a marking and measuring tool, ie. pencil/tape measure - make your mark onto the rubber buffer strips.

Next, completely remove the buffer strip from its channel within the cross-bars and cut out the portion using heavy duty scissors/shears.

NOTE: **DO NOT** dispose of this rubber strip but store it in a secure place to be re-mounted once the accessory has been removed from the rack. This will help reduce wind noise during travel.

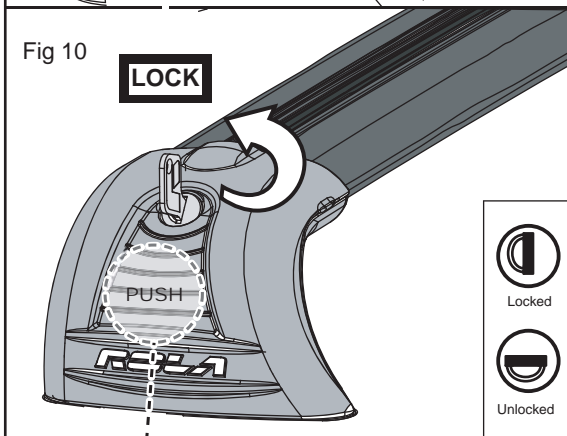

Fig 10

LOCK

PUSH



Locked



Unlocked

STEP 10

Using the 4 keys provided in Covers Kit, proceed to Lock all 4 covers into place by turning the key anti-clockwise. (Fig. 10).

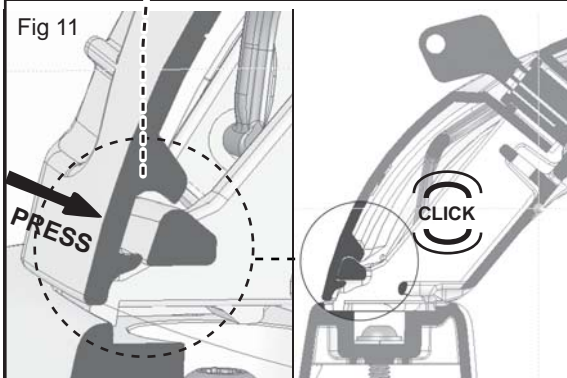

Fig 11

PRESS

CLICK

STEP 11

Ensure ALL End Support covers are pushed hard up against the End Support by pressing the area as indicated in Fig. 10 and Fig. 11.

You should hear an audible "click" when the cover is fully engaged.

Do this for all 4 covers.

Remove the key and store in a safe place - eg. with car keys or glove compartment of the vehicle.

USAGE INSTRUCTIONS

It is essential for the proper assembly, operation and use of the Roof-rack that the instructions and safety precautions supplied are strictly observed.

The Maximum permissible load for your Roof Bar is the lower of the maximum load capacity specified in your vehicle operation manual, or specified as applying to the Roof-rack. Do not exceed the maximum specified Load capacity.

Maximum Permissible Load = Weight of the Roof-rack + Weight of Accessories + Weight of Load(Cargo).

When fitting the Roof-rack and transporting a load, ensure the vehicle's functions are not impaired (eg. sunroof, aerials, windscreen wipers, mirrors). Rear doors on Hatch - and wagon-type vehicles should be inspected for adequate clearance for full opening operation of the boot/tailgate.

Stop and check all screw connections, bolts and retaining straps after a short distance of travel. Repeat these checks at regular intervals.

WARNINGS

Remember that the fitting of a Roof-rack and the transport of a load increases the overall height of the carrying vehicle.

Where the roof-rack is to be used in off-road conditions, a safety weight reduction of 1.5 should be observed from the total carrying capacity (eg. 60kg becomes 40kg).

Cequent will not be liable to the purchaser of any other person for any consequential, direct or indirect loss, damage or costs incurred or suffered by the purchaser or any other person including but not limited to damage to persons or property, loss of turnover, loss of profits, loss of business or goodwill arising from or in relation to the assembly and use of the Roof-rack, or the non-observance of the fitting and care instructions.